

Technical Manual

**STEREO MICRO
INTEGRATED AMPLIFIER RMA-90****STEREO
CASSETTE DECK RMD-90****TABLE OF CONTENTS****PART I: RMA-90**

Specifications	1
Alignment	2
Addendum	2
Parts List	4
Chassis Layout (Top View)	5
P-c Board Diagrams	6
Schematic Diagram	7

PART II: RMD-90

Specifications	9
Alignment	10
Troubleshooting Guide	11
Parts List	14
Disassembly Diagram	15
Chassis Layout (Top View)	17
Block Diagram	17
Schematic Diagram	18
P-c Board Diagrams	20

TABLE DES MATIERES**SECTION I: RMA-90**

Caractéristiques	1
Réglage	3
Addendum	3
Liste des pièces	4
Installation du châssis (vue de dessus)	5
Diagrammes des plaquettes de circuits imprimés	6
Diagramme schématique	7

SECTION II: RMD-90

Caractéristiques	9
Alignement	12
Guide de dépannage	13
Liste des pièces	14
Schéma de démontage	15
Installation du châssis (vue de dessus)	17
Schéma synoptique	17
Diagramme schématique	18
Diagrammes des plaquettes de circuits imprimés	20

PART I

RMA-90 STEREO MICRO INTEGRATED AMPLIFIER

Specifications Caractéristiques

Continuous Power Output30 watts* per channel, min. RMS both channels driven into 8 ohms from 20 to 20,000Hz with no more than 0.03% total harmonic distortion.	Frequency Response:	PHONO30 to 20,000Hz, ± 0.5 dB (RIAA STD)
Total Harmonic Distortion	No more than 0.03% (continuous rated power output) No more than 0.02% (continuous 1/2 rated power output) No more than 0.03% (1 watt per channel power output, 8 ohms)	TUNER, AUX, TAPE5 to 70,000Hz, ± 0.2 dB, -1.0 dB	
Intermodulation Distortion	No more than 0.03% (continuous power output) No more than 0.02% (continuous 1/2 rated power output) No more than 0.03% (1 watt per channel power output, 8 ohms)	Tone Control:	BASS	± 10 dB, 100Hz
Output: Speaker8 ohms	TREBLE	± 10 dB, 10kHz	
Headphone	4-16 ohms	Loudness Contour	± 10 dB (100Hz), $+4$ dB (10kHz) (volume control set at -40 dB position)	
Damping Factor30 (20 to 20,000Hz, 8 ohms)	Signal-to-Noise Ratio (IHF, A network):	PHONO 175dB
Input Sensitivity/Impedance:		TUNER, AUX.95dB	
PHONO (MM)25mV/47 kohms	TAPE MONITOR95dB	
TUNER, AUX.150mV/33 kohms	MISCELLANEOUS		
TAPE MONITOR150mV/33 kohms	Power Requirement120V/60Hz, 220V/50Hz, 240V/50Hz, or 120, 220, 240V/50-60Hz (switchable)	
Overload Level (T.H.D. 0.5%, 1kHz):		Power Consumption275 watts	
PHONO 1130mV	Dimensions (overall)279 (W) x 66 (H) x 262 (D) mm 11" x 2-19/32" x 10-15/16"	
TUNER, AUX, TAPE5V	Weight (net)	4.5kg/99 lbs.	

- Specifications and design subject to possible modification without notice.
- *Measured pursuant to the Federal Trade Commission's Trade Regulation Rule on Power Claims for Amplifiers (applicable to the U.S.A. only).

THE ROTEL CO., LTD.
ROTEL ELECTRONICS CO., LTD.
ROTEL OF AMERICA, INC.
ROTEL HI FI LIMITED.

1-36-8 OHOKAYAMA, MEGURO-KU, TOKYO 152, JAPAN
 2ND FLOOR, EVERGLORY BLDG., NO. 305, SECTION 3,
 NANKING E. ROAD, TAIPEI, TAIWAN, REPUBLIC OF CHINA
 13528 SO. NORMANDIE, GARDENA, CALIF. 90249, U.S.A.
 2-4 ERICA ROAD, STACEY BUSHES, MILTON KEYNES,
 BUCKINGHAMSHIRE, ENGLAND

Alignment

Instruments: Oscilloscope, DC millivoltmeter

POWER AMP SECTION

A. DC Balance Adjustment

1. Set vertical gain control of the oscilloscope to 0.1V/cm, and vertical input switch to GND. Bring the trace to central position on the screen; then set the vertical input switch to DC position.
2. Connect the oscilloscope to pin 9 (8 for R-ch) on H-AF-117 p-c board. Set volume control of the amplifier to minimum position. Turn on the power. When DC output appears on the screen (the trace will shift upwards or downwards as shown in Fig. 1), adjust potentiometer VR601 (VR602 for R-ch) on H-AF-117 p-c board so that the DC voltage present at the test point is $0V \pm 50mV$.

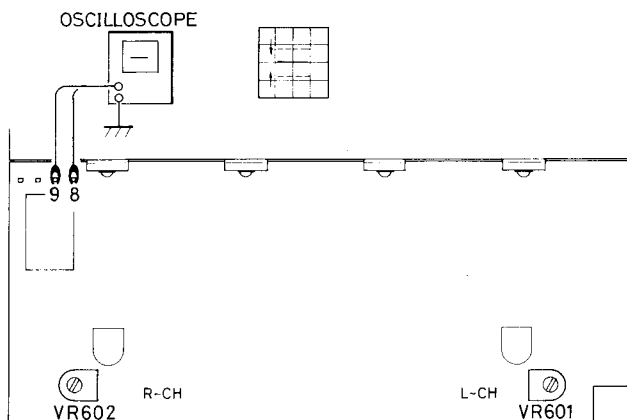

Fig. 1

B. Bias (Idling Current) Adjustment

1. Connect the plus lead of DC millivoltmeter to pin 5 (pin 6 for R-ch) on H-AF-117 p-c board and the minus lead to TP (TP for R-ch). Set volume control to minimum position. Turn on the power.
2. Adjust potentiometer VR603 (VR604 for R-ch) on H-AF-117 p-c board so that the DC millivoltmeter reads 10mV.

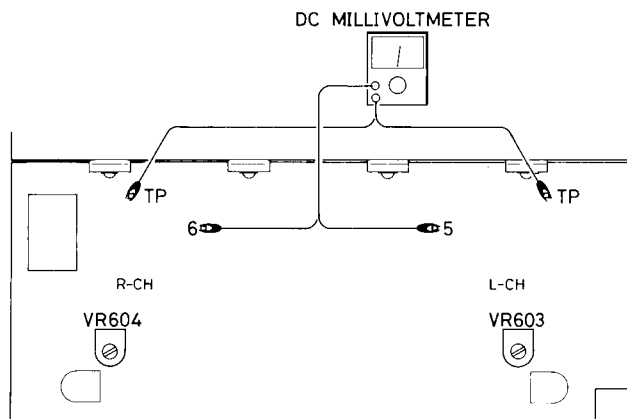

Fig. 2

ADDENDUM

1. The following modifications have been made on the tone control circuit:

Reason: To improve frequency response.

TC-162 p-c board

L-ch	R-ch		
C301	C302	10mfd	→ 22mfd
C303	C304	0.01mfd	→ 0.015mfd
C307	C308	0.1mfd	→ 0.12mfd
R303	R304	33kohms	→ 27kohms
R307	R308	680 ohms	→ 560 ohms
R309	R310	3.3kohms	→ 2.7kohms

H-AF-117 p-c board

C607	C608	10mfd (LN)	→ 33mfd (LN)
------	------	------------	--------------

The above modifications are applicable to the units with serial number beginning NE40001.

Réglage

Instruments: Oscilloscope, millivoltmètre CC

SECTION AMPLI DE PUISSANCE

A. Réglage d'équilibrage CC

1. Régler la commande de gain vertical de l'oscilloscope sur 0,1 V/cm et la commande d'entrée verticale sur GND. Amener la trace en position centrale sur l'écran; amener ensuite la commande d'entrée verticale sur la position CC.
2. Brancher l'oscilloscope sur la broche 9 (8 pour le canal de droite) sur la plaquette H-AF-117. Régler la commande de volume de l'ampli sur la position minimum. Mettre sous tension.
Lorsque la sortie CC apparaît sur l'écran (la trace est décalée vers le haut ou vers le bas comme illustré sur la Fig. 1), ajuster le potentiomètre VR601 (VR602 pour le canal de droite) sur la plaquette H-AF-117 de façon à ce que la tension CC observée sur le point de mesure soit de $0\text{ V} \pm 50\text{ mV}$.

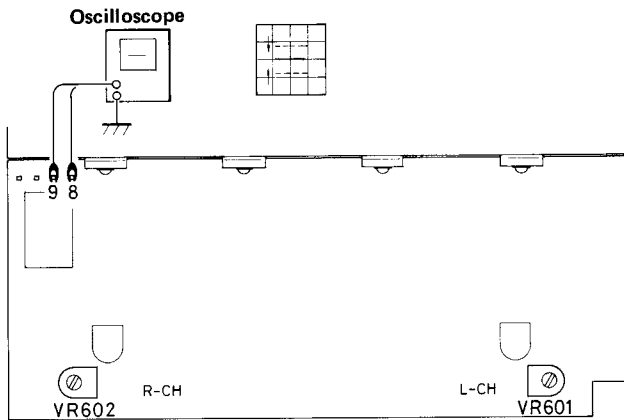

Fig. 1

B. Réglage de polarisation (courant déwatté)

1. Brancher le fil plus du millivoltmètre CC sur la broche 5 (6 pour le canal de droite) de la plaquette H-AF-117 et le fil moins sur TP (TP pour le canal de droite). Régler le volume au minimum. Mettre sous tension.
2. Ajuster le potentiomètre VR603 (VR604 pour le canal de droite) sur la plaquette H-AF-117 de façon à ce que le millivoltmètre affiche 10 mV.

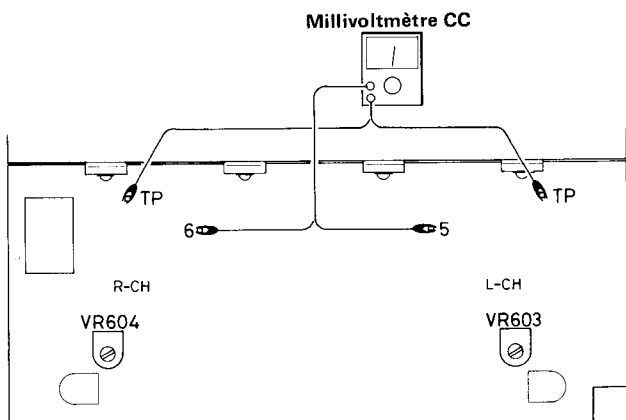

Fig. 2

ADDENDUM

1. Les modifications suivantes ont été apportées au circuit de correction de tonalité:
La raison est la suivante: Aux fins d'amélioration de la courbe de fréquence.

Plaquette à circuits imprimés TC-162

Canal gauche	Canal droit		
C301	C302	10mfd	→ 22mfd
C303	C304	0,01mfd	→ 0,015mfd
C307	C308	0,1mfd	→ 0,12mfd
R303	R304	33K ohms	→ 27K ohms
R307	R308	680 ohms	→ 560 ohms
R309	R310	3,3K ohms	→ 2,7K ohms

Plaquette à circuits imprimés H-AF-117

C607	C608	10mfd (LN)	→ 33mfd (LN)
------	------	------------	--------------

Les modifications mentionnées ci-dessus sont applicables aux appareils dont le numéro de série commencent par NE40001.

Parts List

Liste des pièces

Schematic Location	Description	Part No.
TRANSISTORS, DIODES AND IC'S		
Q401, 901	2SC2274 (E, F)	301201231
Q402	2SC1826 (Y, G)	301201198
Q601, 602, 605, 606, 613, 614, 701, 702	2SC536NP (F, G)	301201234
Q603, 604, 607, 608	2SC930NP (E, F)	301201229
Q609, 610	2SA608NPK (F, G)	301001193
Q611, 612, 619, 620, 621, 622, 633, 634	2SA1016 (G, H)	301001194
Q615 to 618, 623, 624, 635	2SC2362 (G, H)	301201241
Q625, 626	2SD600 (E, F)	301301150
Q627, 628	2SB631 (E, F)	301101134
Q629, 630	2SC2578 (O, Y)	301201235
Q631, 632	2SA1103 (O, Y)	301001190
Q902, 904	2SA608NP (F, G)	301001185
Q903	2SA750 (E, F) or 2SA992 (E, F)	301001133 301001196
D401	WZ-350, Zener, 35V, 0.5W	300313019
D601, 602, 906	WZ-240, Zener, 24V, 0.5W	300313025
D603, 604, 607, 608	KB-269, Varistor	300212004
D605, 606, 611, 612 to 625, 701 to 704, 905	MA150, (Si)	300111016
D609, 610	SV04S, Varistor	300212010
D705 to 708	1K188, (Ge)	300111008
D709, 908	BZ-140, Zener, 14V, 1W	300313005
D751 to 758, 003 to 005	GL-9NG24, LED, (GRN)	300414047
D759 to 761, 001, 002	GL-9PR24, LED, (RED)	300414048
D901, 902	KBP02, Rectifier	300919027
D903, 904	SR1K-4, Rectifier	300919024
D907	WZ-050, Zener, 5V, 0.5W	300313028
D910	BZ-120, Zener, 12V, 1W	300313004
IC101	NJM387DA, Phono Amp	303452263
IC701, 702	AN6875, Level Indicator Driver	303452282
VARIABLE RESISTORS		
VR201, 202	250kW + 100KB x 2, Balance & Volume Control	525121153
VR301, 302	100KC x 2, Bass, Treble Controls	525101166
VR601, 602, 603, 604	10KB, DC Balance Adj, etc.	510502186
SWITCHES		
S1, 2, 3 (1 set)	Push, 5-key, Function, etc.	614051028
S5	Slide, Speaker	613000042
S6	Push, 1-key, Power	614010165
OTHERS		
L601, 602	Anti-parasitic Coil	228641215
T001	Power Transformer D-type (100V/120V Spec) E-type (220V/240V Spec) G-type (T-161G)	204001534 206001534 207001544
RY001	Relay, Speakers	240111248
F801, 802	Fuse, 1.5A or Fuse, F1.6A	341222150 345252160
F803, 804	Fuse, 4A or Fuse, F4A	341222400 345252400
F805* ¹	Fuse, 3A, Primary	341222300
C001	Noise Canceller NSK-135 (100V/120V Spec) NSK-132 (120V CSA Spec) PME265MA447 (220V/240V Spec)	470101118 470101137 470101132

*¹ Not used for 220V/240V spec.

*² Used when G-type power transformer is incorporated.

Schematic Location	Description	Part No.
	Phono and Main Amp P-c Board Ass'y	141610356
	Tone Control, Indicator and Fuse P-c Board Ass'y for 100V/120V Spec for 220V/240V Spec	141811230 141811231
	Phone Jack	626110036
	Voltage Selector* ²	648211247
	Fuse Holder, 2P, for 100V/120V Spec	648211259
	Fuse Holder, 1P, for 100V/120V Spec	648211260
	Fuse Holder, 2P, for 220V/240V Spec	648211266
	LED Holder (12-7), 1	114902387
	LED Holder (12-7), 2	114902388
	LED Socket w/Wire #11	648211274
	LED Socket w/Wire #12	648211275
	LED Socket w/Wire #13	648211276
	LED Socket w/Wire #14	648211277
	LED Socket w/Wire #35	648211296
	Pin Jack, 4P	624208204
	Pin Jack, 6P	624208206
	Speaker Terminal, 4P	642400115
	4P Socket, AC/DC Outlet	648211212
	Sleeve, Power Switch	792011219
	Sleeve, Noise Canceller* ³	792011214
	Cover, Voltage Selector* ²	792011218
	Power Cord, for 120V Spec	796301115
	Power Cord, for 220V Spec	796301148
	Power Cord, for UK only	796301138
	Cord Stopper, STD	675201114
	Cord Stopper, UK only	675201116
	Rubber Sheet #1, $\phi 5 \times \phi 14 \times t2$	990201233
	Felt, Spacer, $\phi 15 \times t5$	990201163
	Insulation Sheet* ²	991001173
	Insulation Sheet	991001176
	Sponge, 180 x 8 x t1	990201337
	Non-woven Cloth, 220 x 6 x t1	990201148
	Non-woven Cloth, $\phi 6 \times \phi 20 \times t1$	990201306
	Non-woven Cloth, $\phi 9 \times \phi 42 \times t1$	990201341
	Wire Clamper	792011218
	Speaker Adaptor* ⁴	625001120
	Ornamental Board, Indicator	120013068
	GND Terminal	770911282
	Front Panel Ass'y	111911586
	Knob, WB, Balance Control	116310354
	Knob, WV, Volume Control	116310355
	Knob, Tone Control	116310304
	Button, $\square 5$	116210094
	Button, 4 x 14	116210092
	Bonnet	138011333
	Foot	673402027
	Owner's Manual	833201420
	Polyethylene Bag, Manual	855002332
	Polyethylene Bag, Set	855004050
	Styrofoam Moulding	815001286
	Packing Case	812001460
	Shipping Carton	816001120
	Screw, M3 x 4 (Ni), Bind	705213004
	Screw, M3 x 6 (Ni), Bind	705213006
	Screw, M3 x 12 (Ni), Bind	705213012
	Screw, M4 x 8 (Ni), Bind	705214008
	Screw, M3 x 6 (Ni), Oval-countersunk	702213006
	Screw, TP3 x 8 (Ni)	726213008
	Screw, TP3 x 10 (Ni)	726213010
	Screw, TP3 x 6 (Ni), Oval-countersunk	722213006
	Screw, TP3 x 8 (Ni), Oval-countersunk	722213008
	Screw, Tap-tight 2.6 x 6 (BLZ), Bind	765222606
	Screw, Tap-tight 4 x 8 (Ni), Bind	765214008
	Screw, Tap-tight, 4 x 8* ²	765214008
	Washer, Flat, M9	770500008
	Spring Washer, M4* ²	770500011
	Nut, M9, Hexagonal	770402207
	Nut, M4, Hexagonal* ²	770402202
	Nut, M7, Hexagonal	770402205
	Jack Stopper	770911278

*³ Not used for 100V/120V spec.

*⁴ OVS only.

Chassis Layout (Top View)

Installation du châssis (vue de dessus)

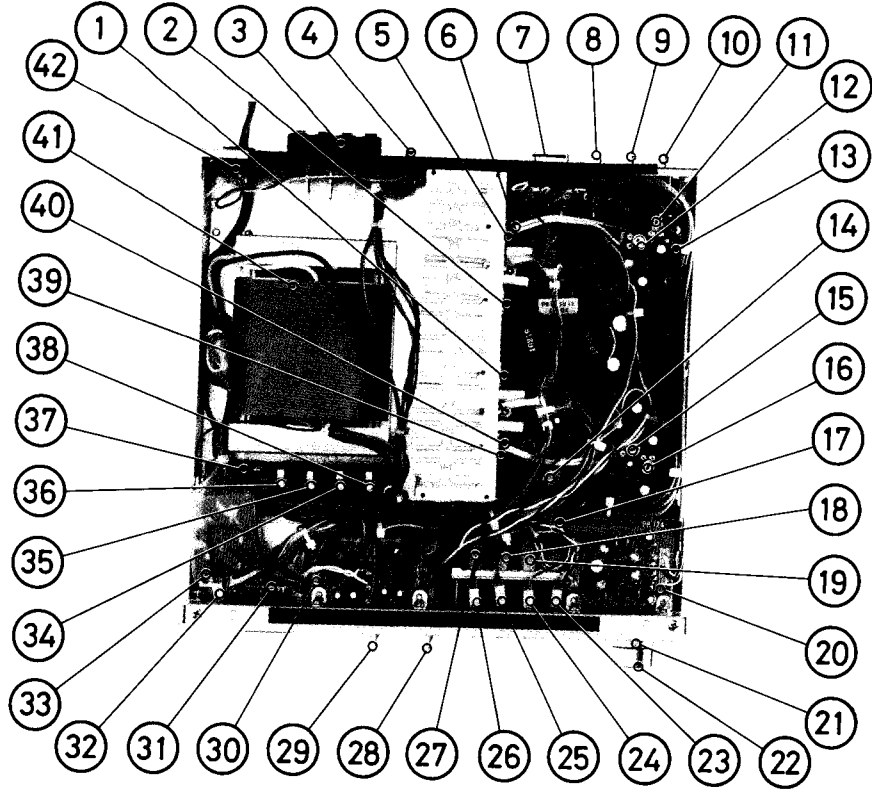

- | | |
|-------------------------------------|---|
| 1. Q630, R-CH POWER TRANSISTOR | 23. PHONO INDICATOR |
| 2. Q629, L-CH POWER TRANSISTOR | 24. TUNER INDICATOR |
| 3. SPEAKER TERMINALS | 25. AUX INDICATOR |
| 4. SPEAKER SWITCH | 26. TAPE INDICATOR |
| 5. Q631, L-CH POWER TRANSISTOR | 27. TAPE SWITCH |
| 6. D609, VARISTOR, L-CH | 28. TREBLE CONTROL |
| 7. TAPE MONITOR JACKS | 29. BASS CONTROL |
| 8. AUX JACK | 30. INDICATOR DRIVER P-C BOARD |
| 9. TUNER JACK | 31. OUTPUT INDICATOR P-C BOARD |
| 10. PHONO JACK | 32. POWER INDICATOR |
| 11. VR601, DC BALANCE ADJ, L-CH | 33. POWER SWITCH |
| 12. VR603, IDLING CURRENT ADJ, L-CH | 34. F802, FUSE, +B |
| 13. MAIN P-C BOARD | 35. F803, FUSE, SECONDARY AC |
| 14. RY601, RELAY | 36. F804, FUSE SECONDARY AC |
| 15. VR604, IDLING CURRENT ADJ, R-CH | 37. FUSE P-C BOARD |
| 16. VR602, DC BALANCE ADJ, R-CH | 38. F801, FUSE, SECONDARY AC FOR TAPE DECK (RMD-90) |
| 17. PHONO SWITCH | 39. Q632, R-CH POWER TRANSISTOR |
| 18. AUX SWITCH | 40. D610, VARISTOR, R-CH |
| 19. TUNER SWITCH | 41. POWER TRANSFORMER |
| 20. PHONO AMP P-C BOARD | 42. DC/AC OUTLET FOR TAPE DECK (RMD-90) |
| 21. BALANCE CONTROL | |
| 22. VOLUME CONTROL | |

PHONO, MAIN AMP AND POWER SUPPLY CIRCUIT

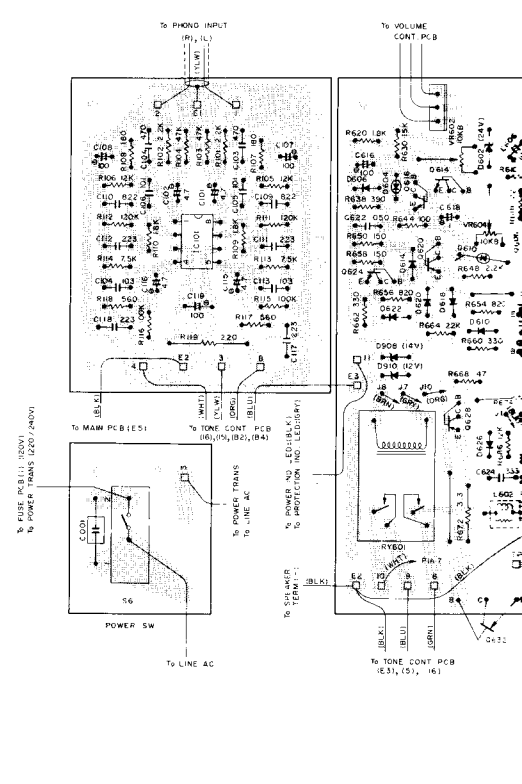

TONE CONTROL, INDICATOR AND FUSE BOARD

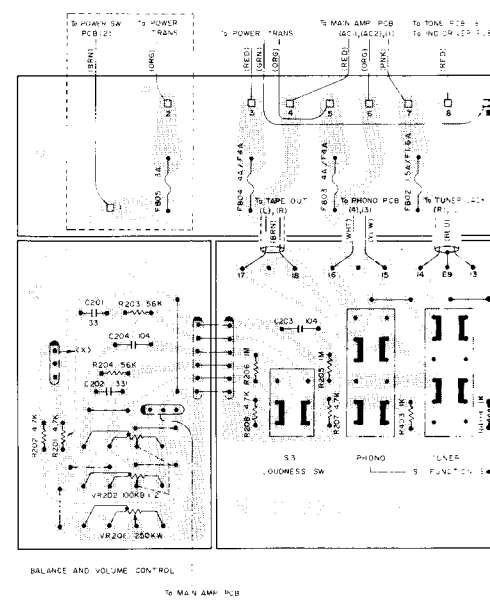

AND POWER SUPPLY CIRCUIT
GRAPHIQUE D'AMPLI PRINCIPAL ET D'ALIMENTATION

Schematic Diagram
Diagramme schématique

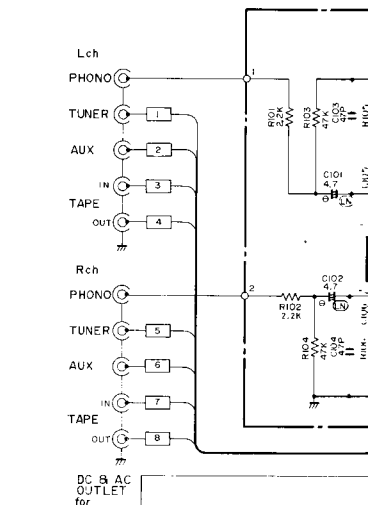
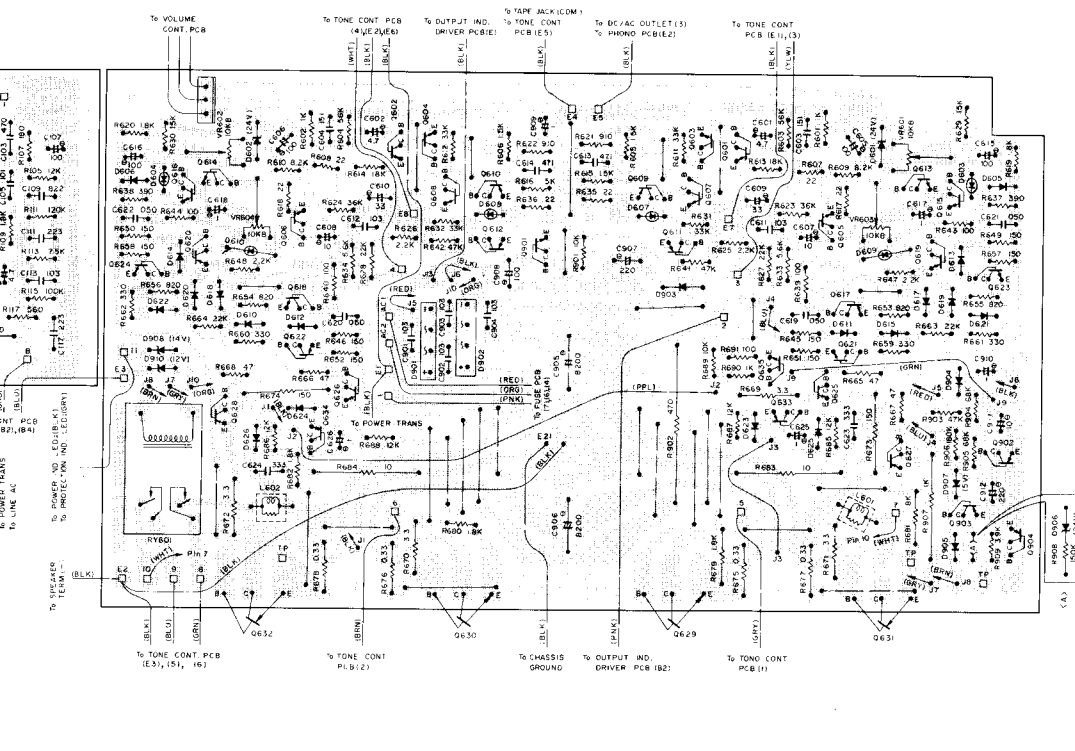

INDICATOR AND FUSE CIRCUIT
MANDE DE TONALITE, DE L'INDICATEUR ET DE FUSIBLE

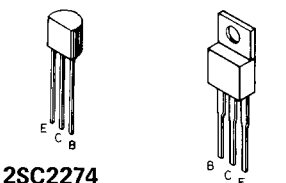
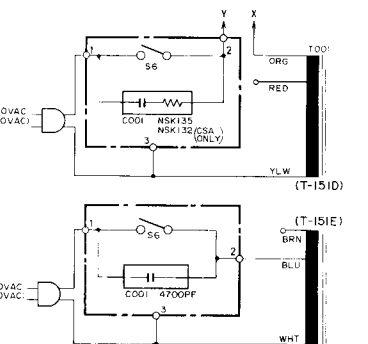
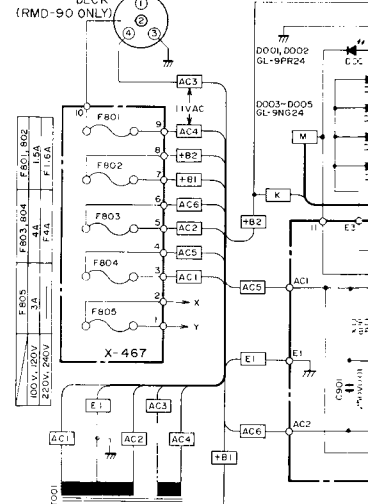
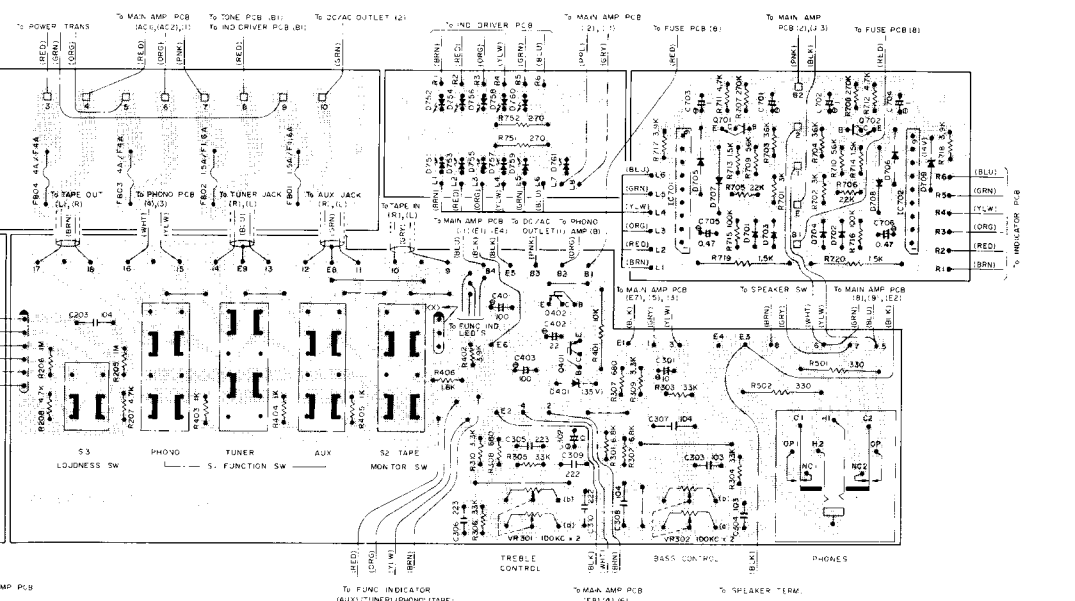

- 2SC2274
- 2SA608NP
- 2SA608KNP
- 2SC930
- 2SA750
- 2SC536NP
- 2SC2362
- 2SA1016
- 2SC1826

Automatic Diagram Schéma schématique

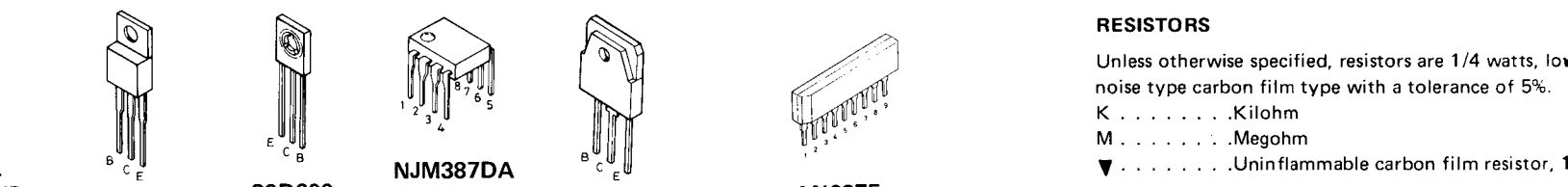
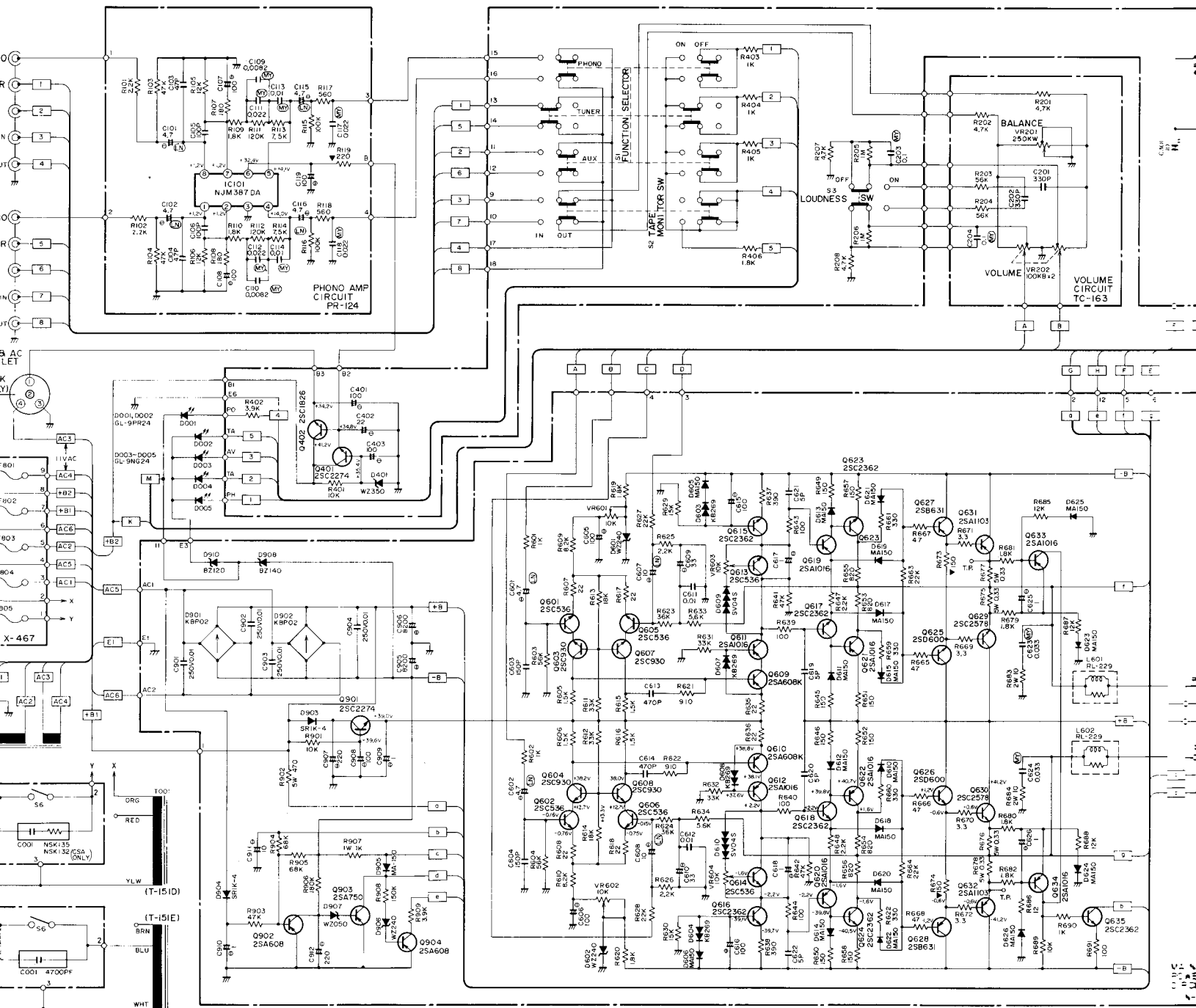

RESISTORS

Unless otherwise specified, resistors are 1/4 watts, low noise type carbon film type with a tolerance of 5%.
 K Kilohm
 M Megohm
 ▼ Uninflammable carbon film resistor, 1/4W

CAPACITORS

Unless otherwise specified, all capacitance values are expressed in mfd.
 MY Mylar film capacitor
 E Electrolytic capacitor
 LN Low noise type
 Non mark Ceramic capacitor

- Voltage read with VTVM across the point shown on the chassis ground (line voltage: 120V)
- Voltage reading tolerance: ±20%

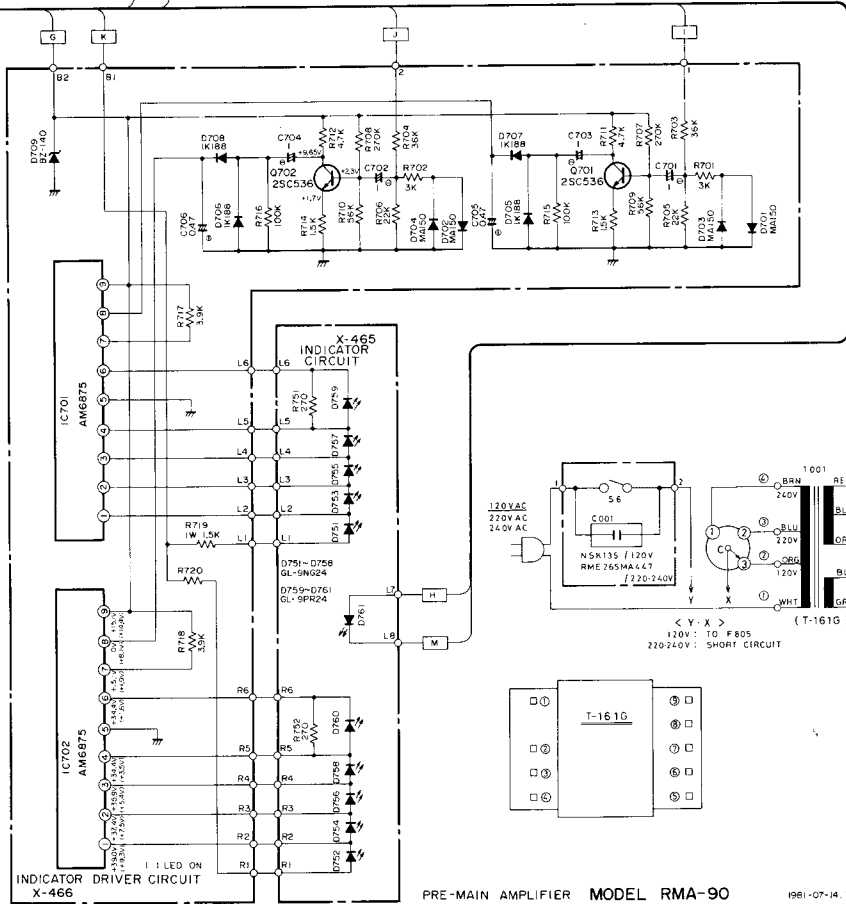
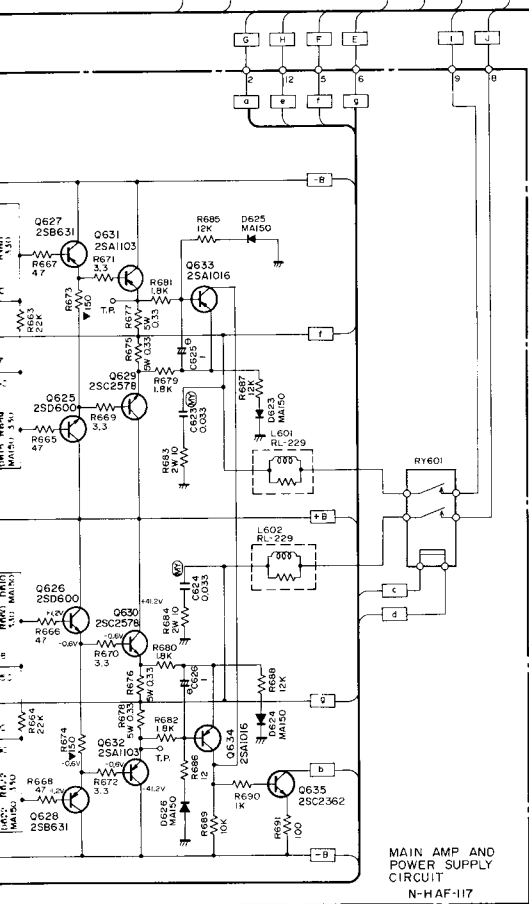
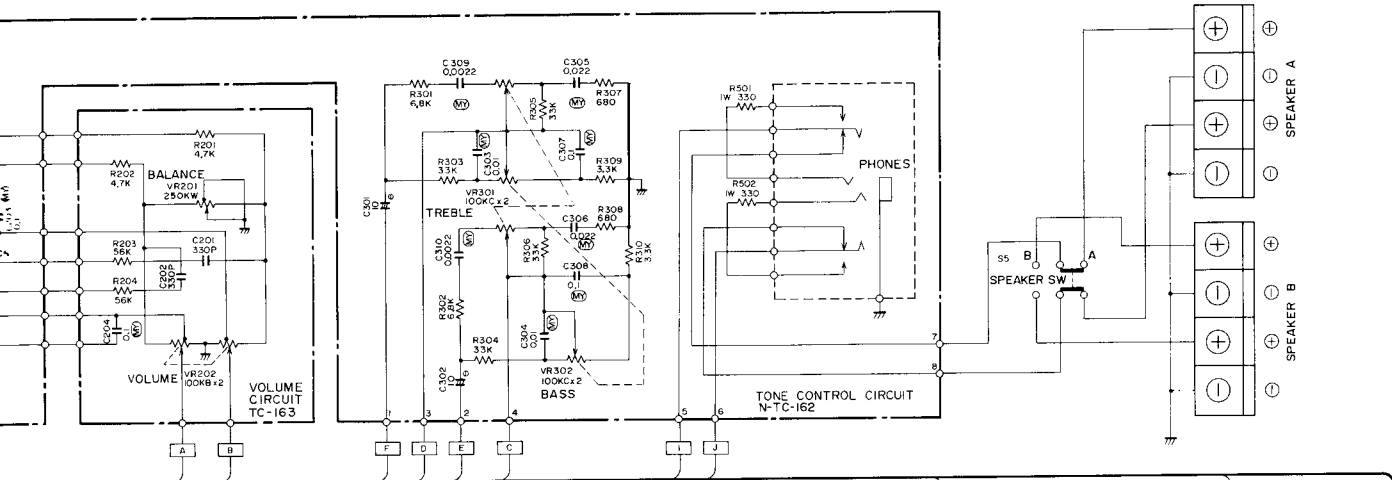

RESISTORS
 otherwise specified, resistors are 1/4 watts, low
 type carbon film type with a tolerance of 5%.
Kilohm
Megohm
Uninflammable carbon film resistor, 1/2 watts

CAPACITORS
 otherwise specified, all capacitance values are
 in mfd.
Mylar film capacitor
Electrolytic capacitor
Low noise type
Ceramic capacitor

Measurement to be read with VTVM across the point shown and
 to chassis ground (line voltage: 120V)
 Measurement tolerance: ±20%

PART II

STEREO CASSETTE DECK

RMD-90

Specifications Caractéristiques

Heads: Rec/Playback	High B Permalloy laminated type
Erase	Double gap ferrite core
Track	4-track/2-channel
Tape Speed	4.8cm/sec.
Motor	Electronic DC Governor (capstan) DC motor (reel)
Wow and Flutter	0.10% (DIN) 0.05% (WRMS)
Distortion (REC/PB, 400Hz)	0.9%
Frequency Response (−20dB):	
Normal, LH30 to 14,000Hz±3dB
Chromium30 to 15,000Hz±3dB
Metal30 to 16,000Hz±3dB
Signal-to-Noise Ratio (WTD. 0dB=580mV, Chromium)	Dolby NR in: 63dB Dolby NR out: 55dB
Input Sensitivity/Impedance. .	MIC 0.45mV/10 kohms LINE 45mV/27 kohms

Output Level/Impedance.	LINE	410mV/2.2 kohms
Fast Wind Time (C-60)90 seconds	
Tape Selector	BIAS	EQUALIZER
Normal, LH100%	120μs
Chromium125%	70μs
Metal185%	70μs

MISCELLANEOUS

Power Requirement.	Power supplied from the amplifier RMA-90
Dimensions (Overall)279 (W) x 115 (H) x 262 (D) mm 11'' x 4-17/32'' x 10-5/16''
Weight (net)3.9kg/8.58 lbs.

- Specifications and design subject to possible modification without notice.
- Dolby, Dolbyized and the double-D symbol are trade marks of Dolby Laboratories.
Noise reduction system manufactured under license from Dolby Laboratories.

Alignment

Instruments: Audio generator, AC VTVM, oscilloscope, test tape (LCT-3004-C and LCT-7001 or equivalent), metal blank tape (Sony Metallic tape)

A. Azimuth Adjustment

1. Set Tape Selector to NORMAL and Dolby NR switch to OFF.
2. Insert the test tape (LCT-3004-C or equivalent) into deck and play it back.
Adjust azimuth screw (Fig. 1) to increase the output levels of both channels at playback to maximum and reduce the difference in output between left and right channels to minimum.
3. After adjustment, fix the azimuth screw with paint.

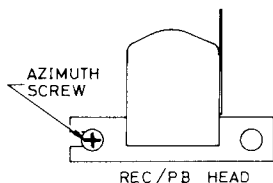

Fig. 1

B. Rec Bias Adjustment

1. Insert metal blank tape into the deck. Set Tape Selector to METAL, Dolby NR switch to OFF, and Rec Level control to maximum.
2. Apply 400Hz signal into LINE IN (L-ch) from the audio generator. Regulate output of the audio generator so that Line Output level is 58mV. Record this signal.
Change the frequency of the audio generator to 10,000Hz (with the input at the same level). Then record the signal.
Adjust potentiometer VR501 on the main p-c board (Fig. 2), by recording and playing back the signal, until outputs for 10,000Hz and 400Hz signals reach the same level.
3. Carry out this adjustment for R-ch, using potentiometer VR502 on the main p-c board.

C. Playback Level Adjustment

1. Set Tape Selector to METAL position, Dolby NR switch to OFF. Connect the AC voltmeter to LINE OUT.
2. Play back test tape LCT-7001 (or equivalent), and adjust potentiometer VR201 (VR202 for R-ch) on the main p-c board (Fig. 2) so that AC voltmeter reads 580mV.

D. Record Level Adjustment

1. Set Tape Selector to METAL position, Dolby NR switch to OFF and Rec Level control to maximum. Connect the audio generator to LINE IN and AC voltmeter and oscilloscope to LINE OUT.
2. Insert metal tape (Sony's Metallic tape) into the deck, and press REC, PLAY and PAUSE buttons. Apply 400Hz (sine wave) signal from the audio generator. Regulate output of the audio generator so that AC voltmeter reads 580mV.
3. Record this signal. Check to see that AC voltmeter reads 580mV when playing back the recorded tape.

4. If recording and playback levels differ from each other, repeat step 3 until the two levels become almost equal, by adjusting potentiometer VR203 (VR204 for R-ch) on the main p-c board (Fig. 2) while recording.

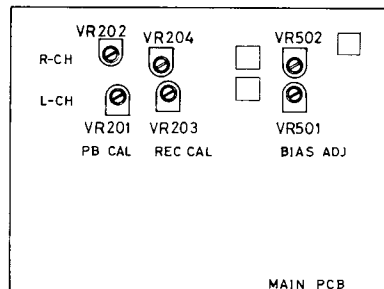
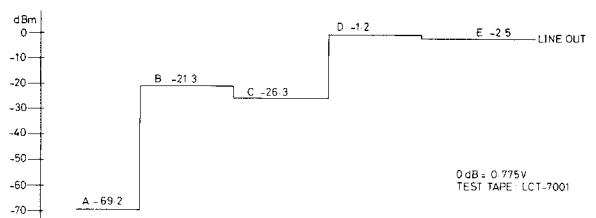
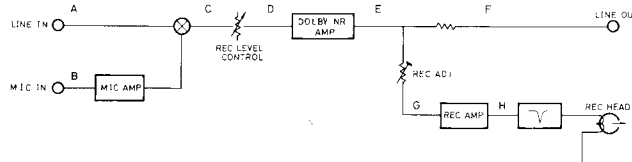
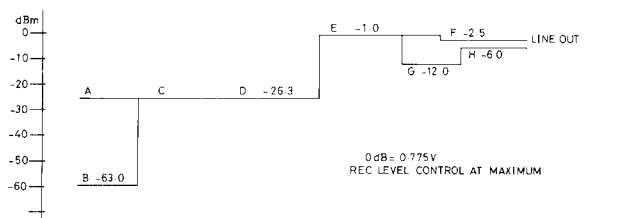

Fig. 2

Record/Playback Level Diagrams



Playback Mode



Recording Mode

Troubleshooting Guide

I. MECHANISM

A. Mechanism inoperative (in REW, F.F. or PLAY)

1. If pilot lamp does not light up.
 - a. No power (11VAC) is supplied from RMA-90.
 - b. Contact failure of primary fuse.
 - c. Blown primary fuse.
 - 1) Deteriorated fuse.
2. If pilot lamp lights up (voltages at B2 and B3 terminals on main p-c board are normal).
 - a. Drive belt comes off or slips.
 - b. Q702 or IC701 on mechanism control circuit is faulty.
 - c. Faulty motor.

B. PLAY does not work

1. Faulty play switch S5
2. Faulty wire connection of play switch.
3. IC701 on mechanism control circuit is faulty.
4. D720, D723, D728, or any one of Q706 through Q716 on mechanism control circuit is faulty.
5. Faulty plunger solenoid, or its wire connection faulty.

Note: In case of items 4 and 5, F.F. or REW function does not work also.

C. F.F. (or REW) does not work

1. Faulty F.F. switch S4 (or REW switch S3)
2. Faulty wire connection of the switch.
3. IC701 on mechanism control circuit is faulty.

D. MEMORY REPEAT does not work

1. Memory switch S9, or its wire connection is faulty.
2. Faulty IC701.

E. Auto-shut-off function does not work

1. Stop sensor S13, or its wire connection is faulty.
2. Q702 or IC701 on mechanism control circuit is faulty.

F. Excessive wow and flutter

1. Decentered or dirty capstan (clinging dirt, etc.)
2. Deformed or dirty pinch roller.
3. Deformed or dirty drive belt.
4. Faulty reel or capstan motor.
5. Faulty Q717 or D725.

II. SIGNAL CIRCUIT

A. Faulty playback operation

1. No output signal appears for either channel.
 - a. Q703 on muting circuit is open.
 - b. Faulty IC701.
 - c. Faulty Q504 or Q505.
2. Output signal appears for a single channel only.
 - a. Faulty Q211, Q213 or Q215 for L-ch (Q212, Q214 or Q216 for R-ch).
 - b. Faulty IC301 for L-ch (IC302 for R-ch).
 - c. Faulty Rec/PB head.
3. Pop noise is generated in playback.
 - a. Faulty Q217 (Q218 for R-ch) on muting circuit.
 - b. Q703 short-circuited.
 - c. Q704, D708 or D715 is open.

B. Faulty recording operation

1. Recording cannot be made on either channel.

- a. Rec switch S6 or S10 is faulty.
 - b. IC701 or D709 is faulty.
 - c. Q703 on muting circuit is faulty (open).
 - d. Faulty Q219 or Q704.
 - e. Faulty Q503, Q504 or Q505.
 - f. Faulty bias oscillating circuit.
 - 1) Q501 or Q502 is faulty.
 - 2) L501 is faulty.
2. Recording can be made only on a single channel.
 - a) Faulty Q229 or Q231 for L-ch (Q230 or Q232 for R-ch).
 - b. Faulty IC301 for L-ch (IC302 for R-ch).
 - c. Faulty Rec/PB head.
 3. Pop noise is generated in recording.
 - a. Q704 on muting circuit is short-circuited, or D710 is open.
 - b. Q704 or Q705 is open.

C. Faulty PAUSE function

1. PAUSE cannot be engaged.
 - a. Faulty PAUSE switch S8.
 - b. Faulty IC701.
2. Pop noise is generated in PAUSE
 - a. D714 is open.

D. Faulty operation of peak level indicator

1. Only one of the indicators works (output signal is normal).

If signal appears at indicator driver input terminals,

 - a. Faulty IC601 for L-ch (IC602 for R-ch).

Alignement

Instruments: Générateur d'audio-fréquences, VTVM CA, Bande d'essai (LCT-3004-C et LCT-7001 ou équivalente), Bande vierge (METAL, Sony Metallic)

A. Réglage de l'azimut

- Régler le sélecteur de bande sur la position NORMAL et mettre l'interrupteur Dolby NR sur OFF.
- Mettre en place et passer la bande d'essai (LCT-3004-C ou équivalente). Régler la vis d'azimut (Fig. 1) pour augmenter le niveau de sortie des deux canaux à la reproduction au maximum et pour réduire au minimum la différence entre les niveaux de sortie des canaux droite et gauche.
- Après avoir effectué le réglage, enduire la vis d'azimut de peinture.

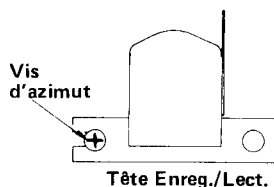

Fig. 1

B. Réglage de polarisation d'enregistrement

- Insérer une bande vierge (METAL) dans la platine de magnétophone. Régler le sélecteur de bande sur METAL, la commande de Dolby sur OFF et la commande de niveau d'enregistrement sur la position maximum.
- Injecter un signal de 400Hz sur la borne LINE IN (canal de gauche) à l'aide d'un générateur de signaux. Ajuster la sortie du générateur de façon à obtenir un niveau de sortie de ligne de 58mV. Enregistrer le signal sur la bande. Modifier le réglage du générateur audio, sur 10.000Hz (l'entrée restant au même niveau). Enregistrer le signal. Ajuster ensuite le potentiomètre VR501 de la plaquette de circuit principal (voir Fig. 2) tout en répétant les opérations d'enregistrement et d'écoute, jusqu'à ce que les sorties correspondant aux signaux de 10.000Hz et 400Hz atteignent le même niveau.
- Effectuer le même réglage pour le canal de droite également, à l'aide du potentiomètre VR502 de la plaquette de circuit principal.

oscilloscope sur la sortie de ligne.

- Insérer une bande vierge (Sony Metallic) dans la platine et presser les commandes REC, PLAY et PAUSE. Injecter un signal de 400Hz (onde sinusoïdale) à partir du générateur audio. Ajuster la sortie du générateur de signaux de façon que le voltmètre CA affiche la valeur 580mV.
- Enregistrer le signal sur la bande. Vérifier que le voltmètre CA affiche bien 580mV lors de la lecture de la bande précédemment enregistrée.
- Si une différence est relevée entre les niveaux d'enregistrement et de lecture, répéter l'opération du point 3 en ajustant le potentiomètre VR203 (VR204 pour le canal de droite) de la plaquette de circuit principal (voir Fig. 2) lors de l'enregistrement.

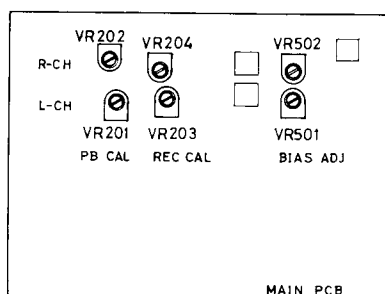
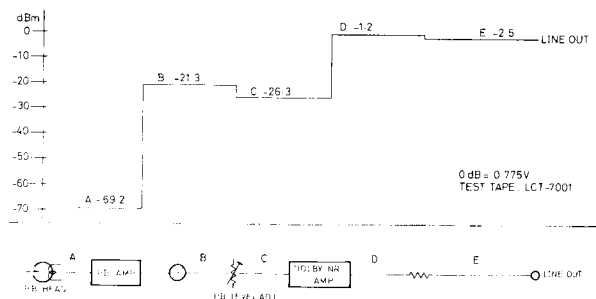

Fig. 2

C. Réglage du niveau de lecture

- Régler le sélecteur de bande sur NORMAL et la commande de Dolby sur OFF. Brancher un voltmètre CA sur la borne de sortie de ligne.
- Procéder à l'écoute de la bande d'essai LCT-7001 ou un équivalent et ajuster le potentiomètre VR201 (VR202 pour le canal de droite) sur la plaquette de circuit principal (voir Fig. 2) de façon à obtenir sur le voltmètre CA un affichage de 580mV.

Diagrammes du niveau d'enregistrement/lecture



Mode de lecture

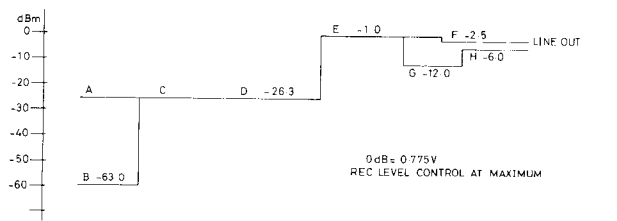

D. Réglage du niveau d'enregistrement

- Régler le sélecteur de bande sur la position METAL, la commande de Dolby sur la position OFF et la commande de niveau d'enregistrement sur la position maximum. Brancher un générateur de signaux audio sur l'entrée de ligne et un voltmètre CA ainsi qu'un

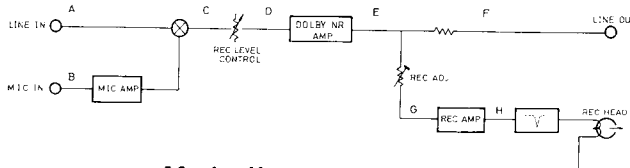

Mode d'enregistrement

Guide de dépannage

I. MECANISMES

A. Mécanisme défaillant (en REW, F.F. ou PLAY)

1. Si la lampe témoin n'est pas allumée.
 - a. Absence d'alimentation (11V de courant alternatif) assurée par RMA-90.
 - b. Défaut de contact du fusible primaire.
 - c. Destruction du fusible primaire
 - 1) Fusible détérioré.
2. Si la lampe témoin est allumée (la tension sur les bornes B2 et B3 de la plaquette du circuit principal est normale).
 - a. La courroie d'entraînement a sauté ou glisse.
 - b. Q702 ou IC701 du circuit de commande du mécanisme sont défaillants.
 - c. Défaillance du moteur.

B. La reproduction ne peut être obtenue

1. Commande de lecture S5 défectueuse.
2. Câblage défectueux de la commande de reproduction.
3. Défaillance de IC701 sur le circuit de commande du mécanisme.
4. Défaillance de D720, D723, D728, Q706, Q707, Q708, Q709, Q710, Q711, Q712, Q713, Q714, Q715 ou Q716 sur le circuit de commande du mécanisme.
5. Défaillance du solénoïde plongeur ou de son câblage.

Note: Dans les cas de pointes 4 et 5, les modes FF ou REW ne peuvent pas non plus être assumés.

C. Le mode FF (ou REW) ne peut être obtenu

1. Défaillance de la commande F.F. S4 (ou de la commande REW S3).
2. Câblage défectueux de la commande.
3. Défaillance de IC701 sur le circuit de commande du mécanisme.

D. La fonction MEMORY REPEAT n'est pas assumée.

1. Commande S9 de mémoire défaillante, ou câblage de la commande défectueux.
2. Défaillance de IC701

E. La fonction d'arrêt automatique n'est pas assumée

1. Défaillance du détecteur d'arrêt S13 ou de son câblage.
2. Défaillance de Q702 ou IC701 sur le circuit de commande du mécanisme.

F. Pleurage et scintillement excessifs

1. Cabestan désaxé ou encrassé (collage d'impuretés, etc.).
2. Déformation ou encrassement du galet d'entraînement.
3. Courroie d'entraînement déformée ou encrassée.
4. Défaillance du moteur de bobine ou de cabestan.
5. Défaillance de Q717 ou D725.

II. CIRCUITS DU SIGNAL

A. Défaillance du mode de reproduction

1. Pas de signal de sortie sur les deux canaux.
 - a. Ouverture de Q703 sur le circuit de silencieux.
 - b. Défaillance de IC701.
 - c. Défaillance de Q504 ou Q505.

2. Le signal de sortie n'est obtenu que sur un seul canal.
 - a. Défaillance de Q211, Q213 ou Q215 pour le canal de gauche (Q212, Q214 ou Q216 pour le canal de droite).
 - b. Défaillance de IC301 pour le canal de gauche (IC302 pour le canal de droite).
 - c. Défaillance de la tête de enregistrement/lecture.
3. Bruit sec de déclenchement lors de la reproduction
 - a. Défaillance de Q217 (Q218 pour le canal de droite) dans le circuit de silencieux.
 - b. Q703 court-circuité.
 - c. Q704, D708 ou D715 ouvert.

B. Défaillance du mode d'enregistrement

1. L'enregistrement ne peut être effectué sur les deux canaux.
 - a. Commande d'enregistrement S6 ou S10 défaillant.
 - b. Défaillance de IC701 ou D709.
 - c. Défaillance de Q703 dans le circuit de silencieux (ouvert).
 - d. Défaillance de Q219 ou Q704.
 - e. Défaillance de Q503, Q504 ou Q505.
 - f. Défaillance du circuit d'oscillation de prémagnétisation.
 - 1) Défaillance de Q501 ou Q502.
 - 2) Défaillance de L501.
2. L'enregistrement ne peut être effectué que sur un canal.
 - a. Défaillance de Q229 ou Q231 pour le canal de gauche (Q230 ou Q232 pour le canal de droite).
 - b. Défaillance de IC301 pour le canal de gauche (IC302 pour le canal de droite).
 - c. Défaillance de la tête d'enregistrement/lecture.
3. Bruit sec de déclenchement lors de l'enregistrement
 - a. Q704 dans le circuit de silencieux est court-circuité ou D710 est ouvert.
 - b. Q704 ou Q705 est ouvert.

C. Défaillance de la fonction PAUSE

1. Le mode de pause ne peut être enclenché.
 - a. Défaillance de la commande de pause S8.
 - b. Défaillance de IC701.
2. Bruit sec de déclenchement en mode de PAUSE
 - a. D714 est ouvert.

D. Défaillance du fonctionnement de l'indicateur de niveau

1. Un seul indicateur fonctionne (le signal de sortie étant normal).

Si le signal est présent sur les bornes d'entrée du driver de l'indicateur.

 - a. Défaillance de IC601 pour le canal de gauche (IC602 pour le canal de droite).

Schematic Location	Description	Part No.	Schematic Location	Description	Part No.
TRANSISTORS, DIODES AND IC'S			OTHERS		
Q101, 102, 211, 212, 213, 214	2SC1571 (G)	301201228	Main P-c Board Ass'y (including X-446 to X-449 & X-468 PCB Ass'y) Mechanism Controller P-c Board Ass'y (including X-432 - X-438 PCB Ass'y) Cassette Mechanism Ass'y w/Controller P-c Board Ass'y Tape Counter Belt, Counter, ϕ 31.5 Shaft Ass'y, Relay DIN Socket, 8P Pin Jack, 4P Mic Jack Holder, LED LED Socket w/Red Wire, L=150 LED Socket w/Brown Wire, L=150 Power Supply Cord w/4P Plug Cord Stopper Foot Signal Cord Ass'y Front Panel Ass'y Upper Cover Lower Cover Head Cover Knob, Rec Level Control, L-ch Knob, Rec Level Control, R-ch Button, Tape Selector, etc. Button, Key-board, PLAY, STOP Button, Key-board, REC, FF, etc. Button, Memory Repeat Top Cover Sponge, 180 x 8 x 1 Sponge, Key-board SW Felt, ϕ 9 x ϕ 42 x t1 Felt, 220 x 6 x 1 Cover, Switch Stopper, Jack PE Bag, Booklet PE Bag, Set Packing Case Shipping Carton Box Stylofoam Screw, M3 x 4 (Ni), Bind Screw, M3 x 6 (Ni), Bind Screw, M3 x 6 (Ni), Oval-countersunk Screw, M3 x 12 (Ni), Bind Screw, TP 2 x 8 (Ni), Pan Screw, TP3 x 6 (Ni), Oval-countersunk Screw, TP3 x 8 (Ni) Screw, TP3 x 8 (BLZ) Screw, TP3 x 8 (Ni), Oval-countersunk Screw, Tap-tight 2.6 x 6 (BLZ), Bind Nut, M3, Square Nut, M9, Hexagonal Washer, Flat, ϕ 3.2 x ϕ 8 x t0.5 Washer, Flat, ϕ 9.5 x ϕ 13 x t0.8 Washer, Spring, M3 Insulation Collar, Tr Mtg	141811226	
Q201 to 204, 209, 210, 215, 216, 221, 501, 504, 703				2SC536NP (F, G)	301201234
Q207, 208, 217, 218, 219, 220, 227 to 230, 504, 505, 704, 705, 708, 711, 717, 719	2SC536NP (F, G) or 2SC1815 (GR)	301201234 301201244		650901117 671011025 654101158 625001121 624303204 627117829 114902329 648211274 648211275 791001168 675201114 678402027 791001112 111911584 114902384 114902385 114902350 116310328 116310326 116210092 116210110 116210113 116210094 138011332 990201337 990201343 990201341 990201148 991001180 770911278 855002332 855004050 812001458 816001117 815001287 705213004 705213006 702213006 705213012 723212008 722213006 726213008 726223008 722213008 765222606 770911144 770402207 770500003 770500008 770500010 992001111	
Q205, 206, 231, 237, 503, 702	2SA608NP (F, G)	301001185			
Q223 to 226	2SC930NP (E)	301201249			
Q502	2SD600 (E, F)	301301150			
Q506	2SC1826 (O, Y, G)	301201169			
Q701, 707, 710, 712, 713, 716, 718	2SC2274 (E, F) or 2SC1318 (R, S)	301201231 301201155			
Q706, 709, 714, 715	2SA984 (E, F) or 2SA720 (R, S)	301001188 301001139			
D201, 202, 501, 502, 503, 702, 703 to 707, 709 to 715, 720 to 724, 726 to 729	1S1588, (Si) or MA-150, (Si)	300111018 300111016			
D401, 613, 614, 615 to 620, 902, 903	GL-9PR24, LED, (RED)	300414048			
D402, 601, 602, 603 to 612, 901	GL-9NG24, LED, (GRN)	300414047			
D504	KBP02, Rectifier	300919027			
D505	WZ-240, Zener, 24V, 0.5W	300313025			
D701, 725	WZ-056, Zener, 5.6V, 0.5W	300313031			
D708	WZ-050, Zener, 5V, 0.5W	300313028			
D716 to 719	SR1K-4, Rectifier	300919024			
IC301, 302	NE646B, Dolby NR System	303452218			
IC601, 602	BA683, Level Indicator Driver	303452253			
IC701	TC9121P, Logic Control	303452221			
COILS					
L201, 202	MPX Filter	228641181			
L203, 204	Bias Carrier Trap	228641182			
L401, 402	Peaking, 12mH	228641205			
L501	Bias OSC Trans	228641216			
L502	Choke, 560 μ H	226501196			
VARIABLE RESISTORS					
VR201, 202	Pot, 50KB, Play Cal	510502191			
VR203, 204	Pot, 5KB, Rec Cal	510502188			
VR301	50KA, Rec Level Control	525101182			
VR501, 502	Pot, 100KB, Bias Adj	510502210			
SWITCHES					
S1, 2 (1 set)	Push, 4-key, Tape Selector, etc.	614040843			
S3 to 8	Touch, Mech Control	615212297			
S9	Push, 1-key, Memory	614010167			
S13	Read, Stop Sensor	615212262			

Disassembly Diagram

Schéma de démontage

No.	Description	Part No.
1.	Chassis Ass'y	090241001
2.	Bracket, (R), Lever	090241002
3.	Bracket, (L), Lever	090241003
4.	Springy Plate	090246301
5.	Slide Ass'y, (P-1)	090241004
6.	Slide Ass'y, (P-2)	090241005
7.	Bracket Lever Ass'y	090241006
8.	Bracket Ass'y, Plunger Solenoid	090241007
9.	Lever, Link	090241008
10.	Not used	-
11.	Rubber Tube, Stopper	090246324
12.	Rubber Tube, Brake	090246325
13.	Not used	-
14.	Spring, Expansion	090246302
15.	Not used	-
16.	Spring, Expansion	090246303
17.	Spring, Brake	090246304
18.	Plunger Solenoid (w/YLW wire), P-1	090242101
19.	Plunger Solenoid (w/GRN wire), P-2	090242102
20.	Flywheel Ass'y	090246305
21.	Bearing Ass'y	090241024
22.	Belt, Main	090246306
23.	Lever Ass'y, Pinch Roller	090241009
24.	Lever Ass'y, Pressure	090241010
25.	Spring, Expansion	090246307
26.	Lever, Cassette Hold	090241011
27.	Torsion Spring (R)	090246308
28.	Torsion Spring (L)	090246309
29.	Spring, Leaf	090246310
30.	Bracket	090241012
31.	Slide Ass'y, Head Mtg	090241013
32.	Rec/PB Head	241001118
33.	Erase Head	241001123
34.	Spring, Compression	090246311
35.	Wire Ass'y, Chassis Ground	090247101
36.	Lug, Wire Clamp	090247102
37.	Lug, Wire Clamp	090247103
38.	Not used	-
39.	Reel Base Ass'y	090241014
40.	Lever Ass'y, FR Roller	090241015
41.	FR Roller	090246312
42.	Reel Ass'y, Take-up/Supply	090246313
43.	Not used	-
44.	Lever	090241016
45.	Plate, Back Tension	090241017
46.	Felt	090249001
47.	Shaft	090246314
48.	Pulley, Reel Motor	090246315
49.	Cap, Reel	090246316
50.	Belt, Counter	671011024
51.	Spring, Compression	090246317
52.	Torsion Spring	090246318
53.	Motor, Reel	090242103
54.	Bracket, Capstan Motor	090241018
55.	Pulley, Capstan Motor	090246319
56.	Screw, Thrust	090247104
57.	Cushion, Motor	090246320
58.	Motor, Capstan	090242104
59.	Protection Lever, Mis-erase	090241019
60.	Torsion Spring	090246321
61.	Bracket, Rec SW	090241020
62.	Bracket, Lamp	090241021
63.	Protector, Eject SW	090241022
64.	Switch, Rec	090246322
65.	Switch, Eject	090246323
66.	Lamp, 14V, 40mA	359101130
67.	Lamp Cover (Blue)	090247105
68.	Lug, Wire Clamp	090247106
69.	Bracket, PC-board	090241023
70 to 101.	Not used	-
102.	Screw, M2 x 3, Pan	703202003
103.	Screw, M2 x 7, Pan	703202007
104.	Not used	-
105.	Screw, M2.6 x 3, Pan	703202603

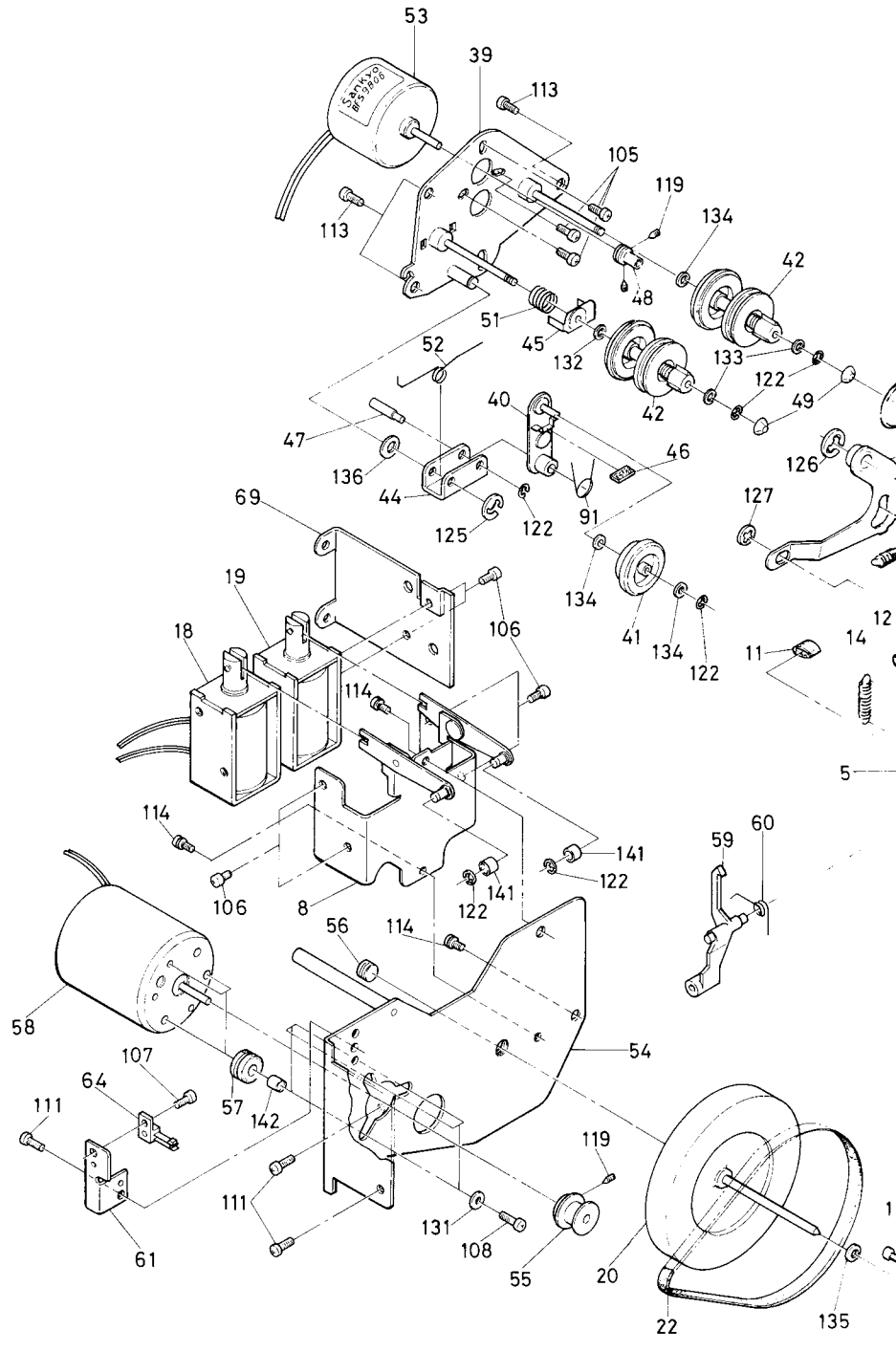

106.	Screw, M2.6 x 4, Pan	703202604	126.	ETW-4
107.	Screw, M2.6 x 5, Pan	703202605	127.	CSTW-3
108.	Screw, M2.6 x 8, Pan	703202608	128 to 130	
109.	Screw, M2.6 x 8, Bind	705202608	131.	Washer,
110.	Screw, M2.6 x 4, Tap-tight, Pan	763202604	132.	Polyslide
111.	Screw, M2.6 x 5, Tap-tight, Pan	763202605	133.	Polyslide
112.	Not used	-	134.	Polyslide
113.	Screw, Tapping, 3 x 6, Pan	723203006	135.	Polyslide
114.	Screw, M2.6 x 4 w/SPW, Pan	713202604	136.	Polyslide
115.	Screw, M2.6 x 5 w/SPW, Pan	713202605	137.	Nylon W
116 to 118.	Not used	-	138.	Nylon W
119.	Set Screw, M2 x 2	770911300	139 to 140.	
120.	Not used	-	141.	Spacer, c
121.	Steel Ball, ø2	651010113	142.	Spacer, c
122.	ETW-1.5	770500026		
123.	ETW-1.9	770500044		
124.	ETW-2.3	770500057		
125.	ETW-3	770500039		

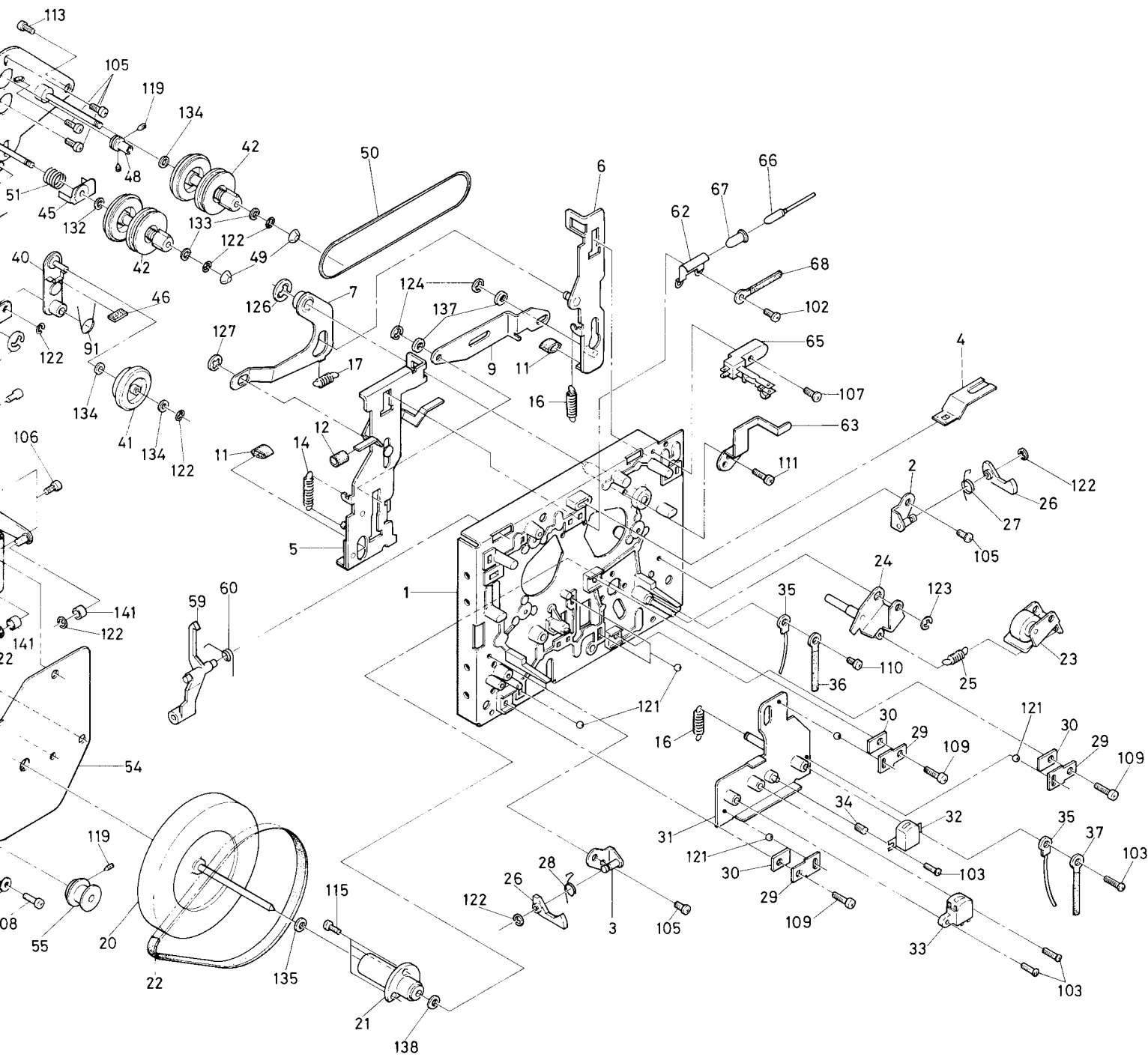

- | | | |
|-----------|--|-----------|
| 703202604 | 126. ETW-4 | 770500040 |
| 703202605 | 127. CSTW-3 | 770911252 |
| 703202608 | 128 to 130 Not used | - |
| 705202608 | 131. Washer, Plain $\phi 2.8 \times \phi 10 \times t0.3$ | 090247109 |
| 763202604 | 132. Polyslider Washer, $\phi 2 \times \phi 4 \times t0.13$ | 770500094 |
| 763202605 | 133. Polyslider Washer, $\phi 2 \times \phi 4 \times t0.25$ | 770500095 |
| - | 134. Polyslider Washer, $\phi 2 \times \phi 4 \times t0.5$ | 770500096 |
| 723203006 | 135. Polyslider Washer, $\phi 2.6 \times \phi 5 \times t0.5$ | 770500097 |
| 713202604 | 136. Polyslider Washer, $\phi 4 \times \phi 10 \times t0.5$ | 770500098 |
| 713202605 | 137. Nylon Washer, $\phi 3 \times \phi 5 \times t0.5$ | 770500099 |
| - | 138. Nylon Washer, $\phi 2.4 \times \phi 6 \times t0.5$ | 770500056 |
| 770911300 | 139 to 140. Not used | - |
| - | 141. Spacer, $\phi 3 \times \phi 4 \times L3.5$ | 090247107 |
| 651010113 | 142. Spacer, $\phi 3 \times \phi 4 \times L6$ | 090247108 |
| 770500026 | | |
| 770500044 | | |
| 770500057 | | |
| 770500039 | | |

Chassis Layout (Top View)

Installation du châssis (vue de dessus)

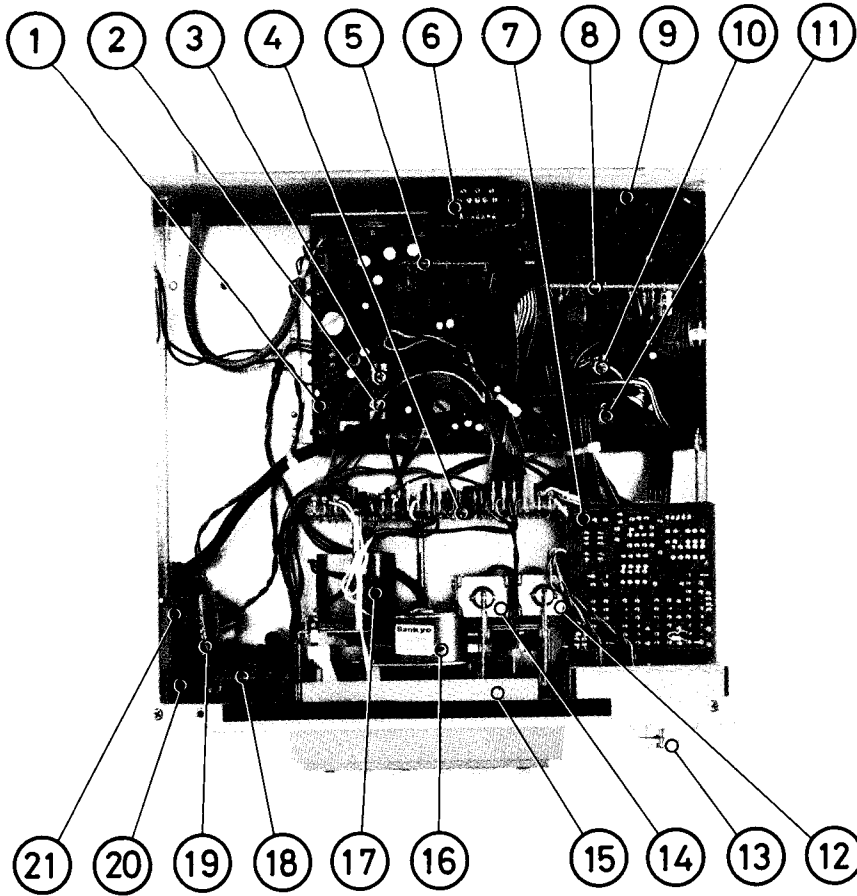

1. MAIN P-C BOARD
2. VR502, BIAS ADJ (R-CH)
3. VR501, BIAS ADJ (L-CH)
4. MECHANISM CONTROLLER P-C BOARD
5. DOLBY NR P-C BOARD, (L-CH)
6. REMOTE CONTROL INPUT SOCKET P-C BOARD
7. TAPE SELECTOR P-C BOARD
8. DOLBY NR P-C BOARD, (R-CH)
9. LINE IN/OUT JACKS
10. VR201, PLAYBACK CAL, (L-CH)
11. VR202, PLAYBACK CAL, (R-CH)
12. PLG002, PLUNGER SOLENOID
13. REC LEVEL CONTROL KNOB
14. PLG001, PLUNGER SOLENOID
15. MECHANISM ASS'Y
16. REEL MOTOR
17. CAPSTAN MOTOR
18. LEVEL INDICATOR P-C BOARD
19. LEVEL INDICATOR DRIVER P-C BOARD
20. MIC JACK
21. MIC AMP P-C BOARD

Block Diagram

Schéma synoptique

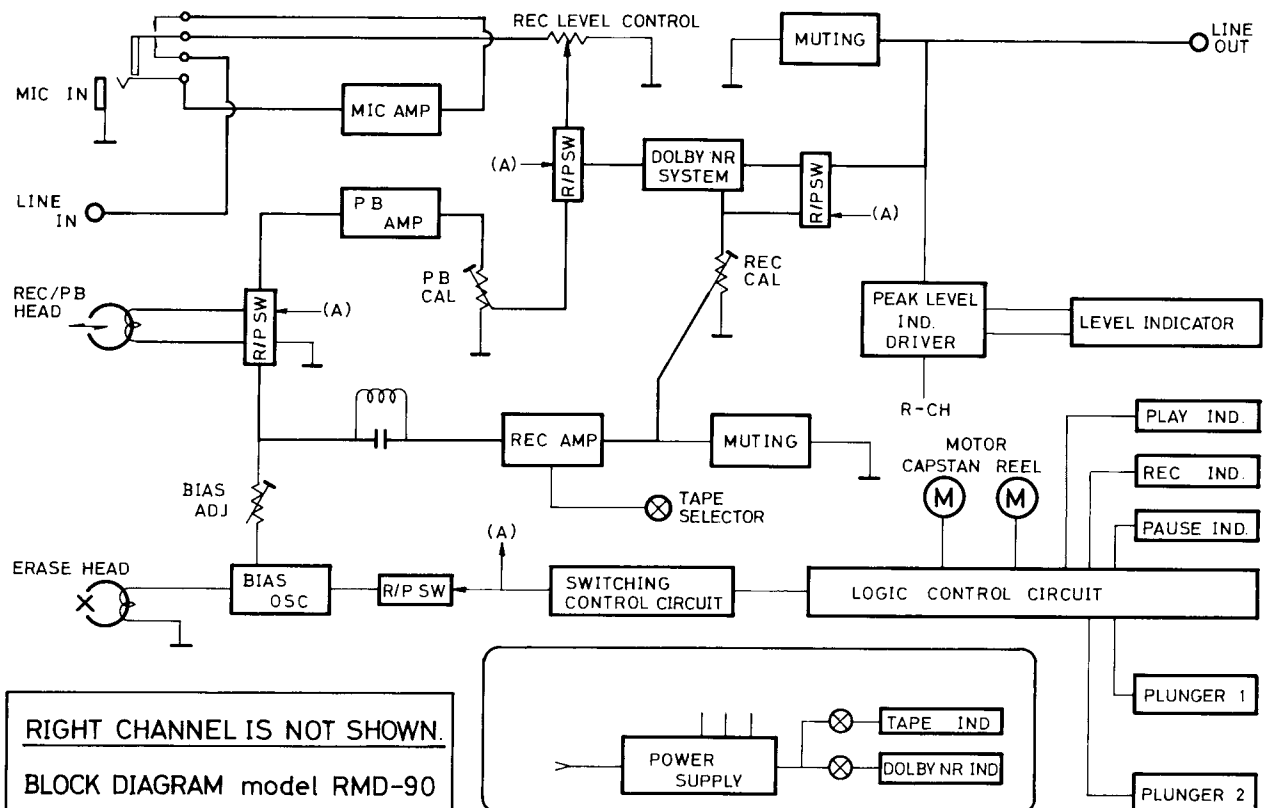

Schematic Diagram

Diagramme schématique

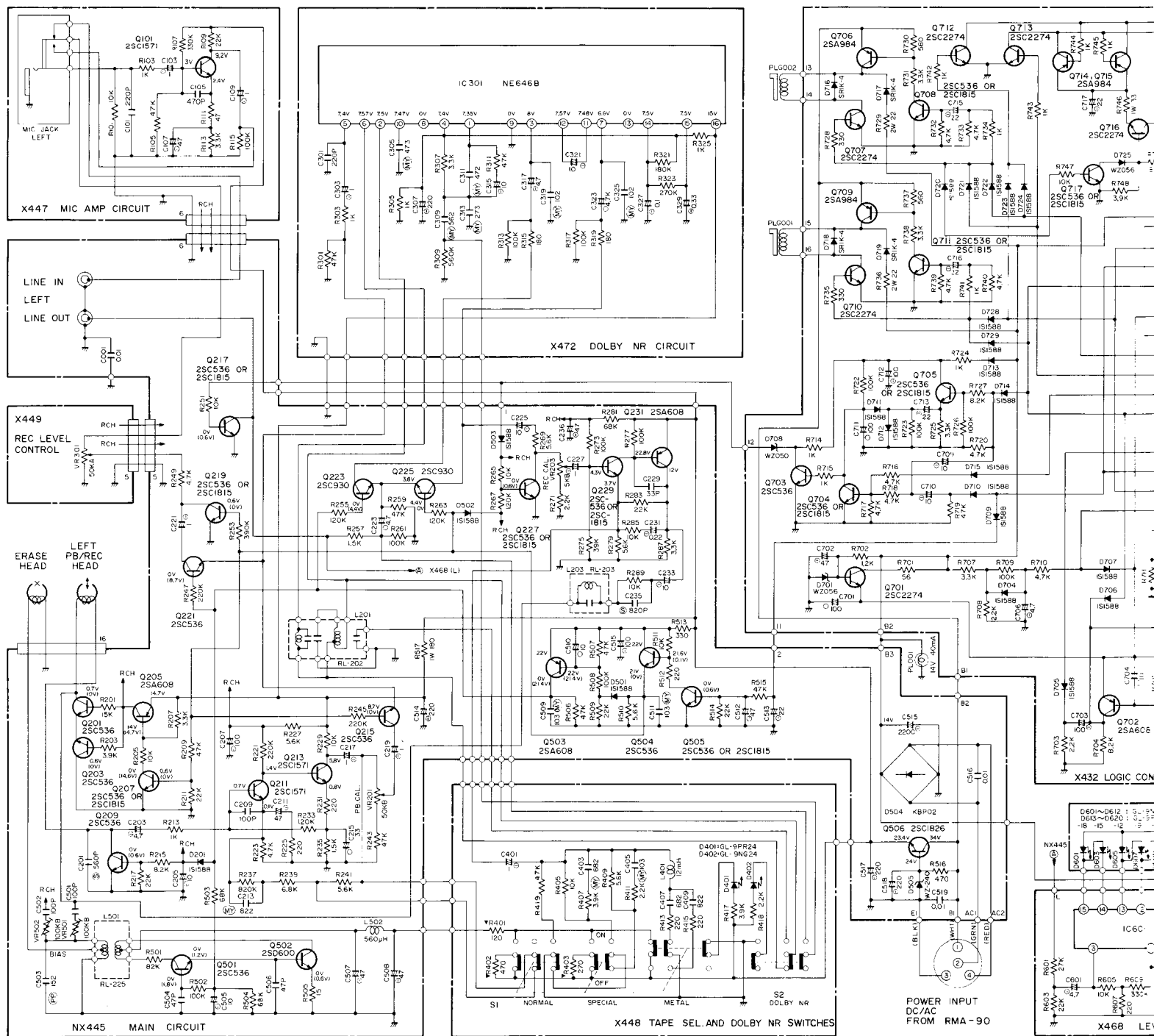

2SC2274
2SA984
2SA608NP
2SC1815
2SC930
2SC536NP
2SC1571



2SC1826

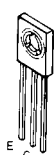

2SD600

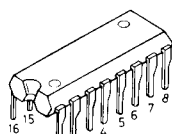

NE646B

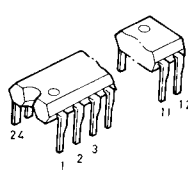

TC9121P

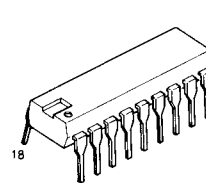

BA683

RESISTOR

Unless otherwise specified, all resistors are in ohms unless otherwise specified.
K... Kilohms
M... Megohms
▼... Non-standard values

CAPACITOR

Unless otherwise specified, all capacitors are in picofarads unless otherwise specified.
Ⓢ... Microfarads
Ⓜ... Millifarads
Ⓟ... Picofarads
—||—... Non-standard values

- Voltage
- Current
- Power

MAIN CIRCUIT CIRCUIT PRINCIPAL

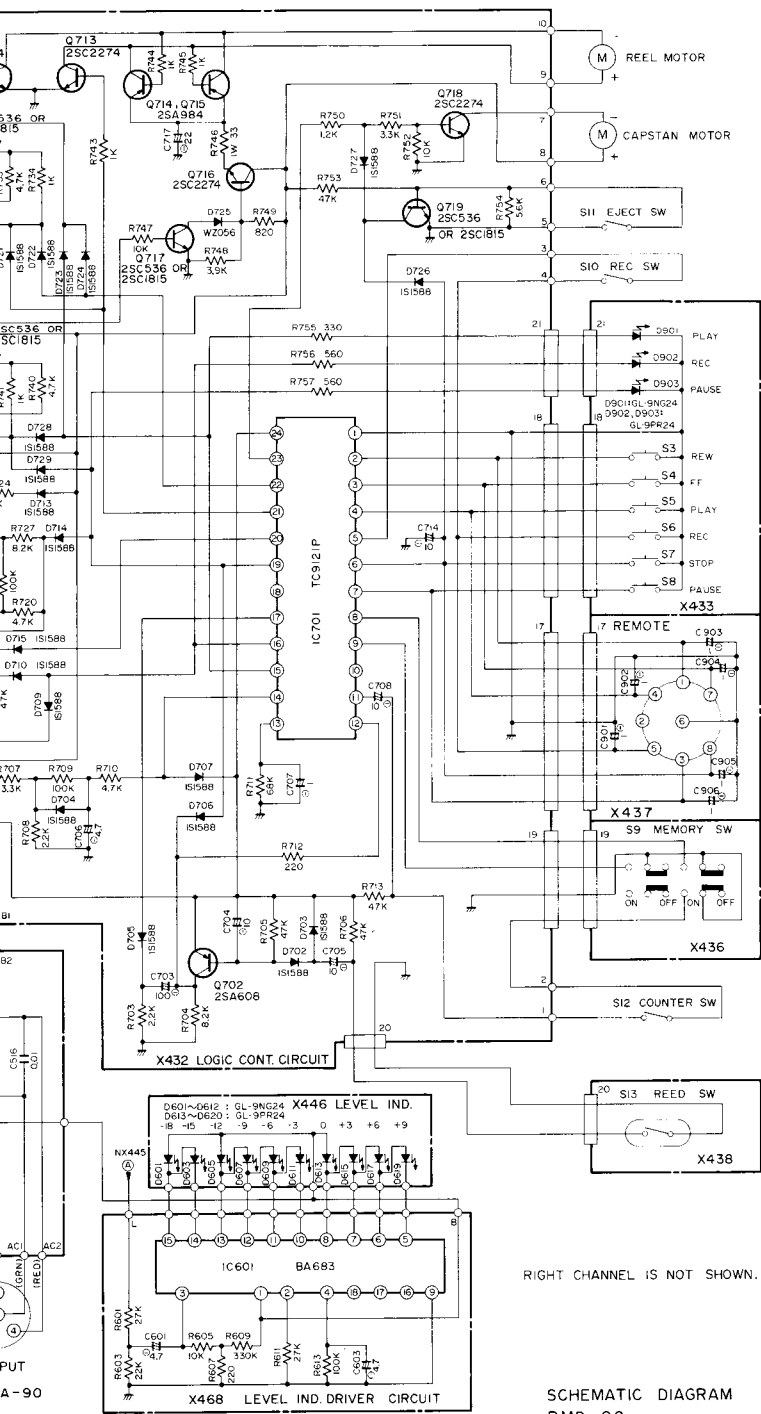

RESISTORS

Unless otherwise specified, resistors are 1/4 watts, low noise type carbon film type with a tolerance of 5%.

K Kilohm

M Megohm

▼ Uninflammable carbon film resistor, 1/2 watts

CAPACITORS

Unless otherwise specified, all capacitance values are expressed in mfd.

Ⓢ Polystyrene film capacitor

Ⓜ Mylar film capacitor

Ⓟ Polypropylene film capacitor

—H— Electrolytic capacitor

Non mark Ceramic capacitor

- Voltage read with VTVM across the point shown and the chassis ground (line voltage: 120V)
- Voltage reading tolerance: ±20%

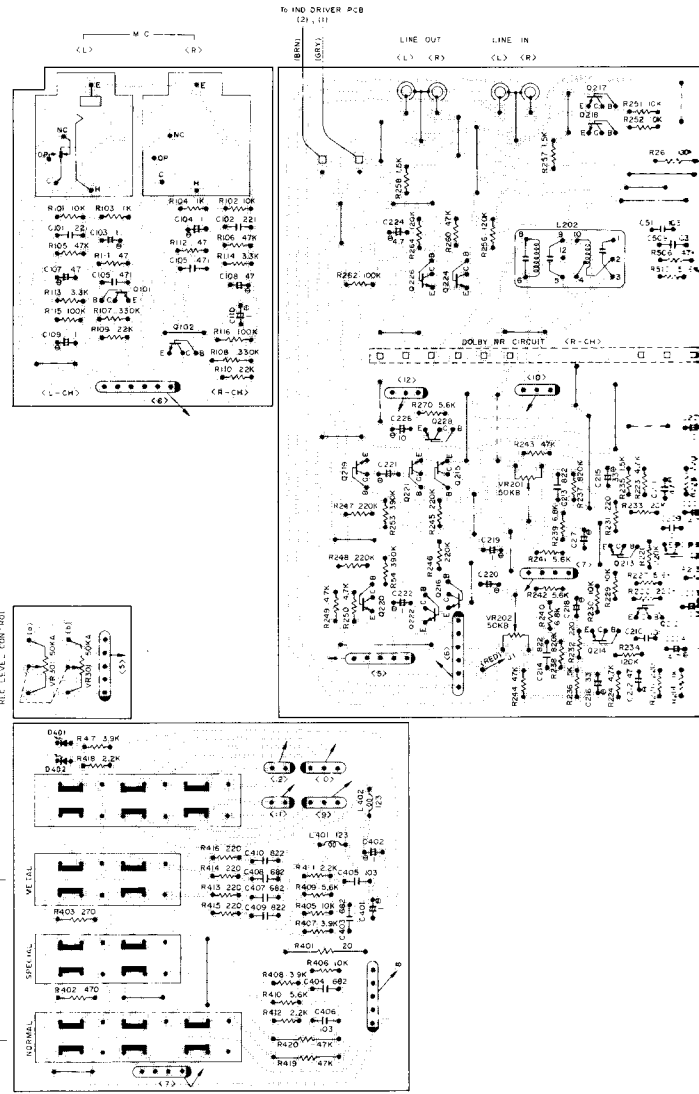

MECHANISM CONTROLLER CIRCUIT CIRCUIT DE COMMANDE DU MECANISME

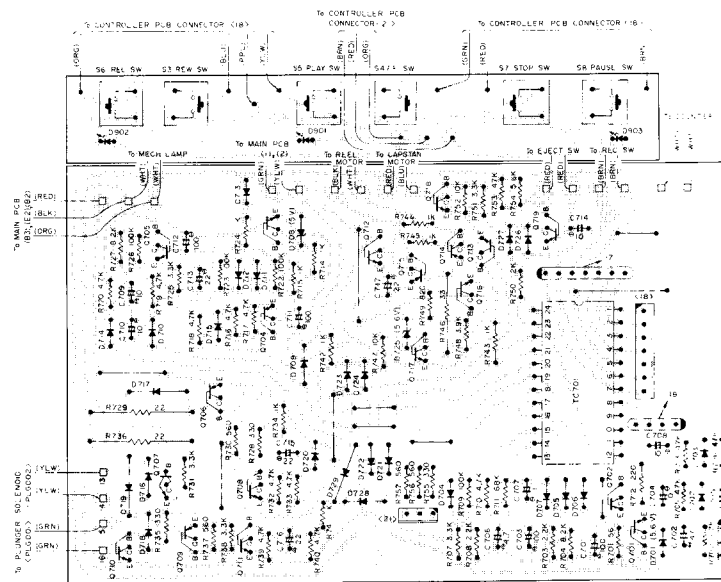

Circuit Principal

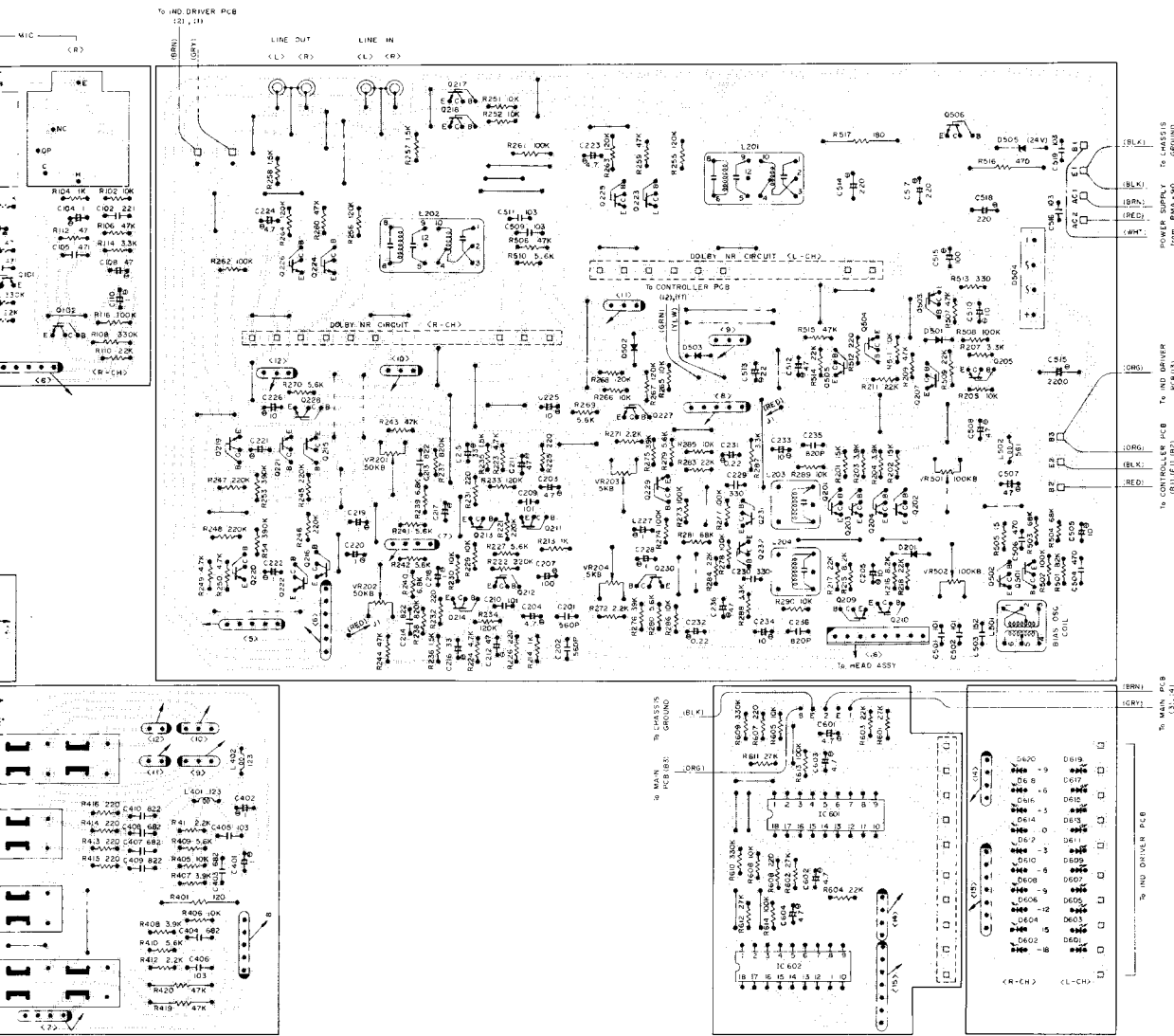

**CONTROLLER CIRCUIT
CIRCUIT DE COMMANDE DU MECANISME**

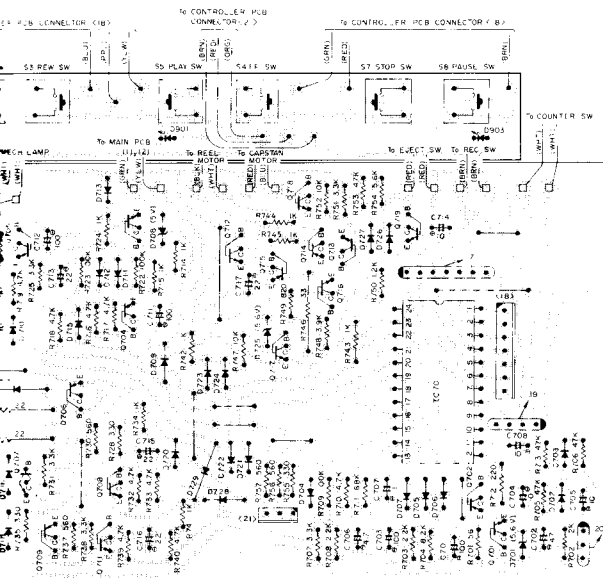

**DOLBY NR CIRCUIT
CIRCUIT DOLBY NR**

